

Soldering Station ESD Safe & Temperature-Adjustable

OPERATION INSTRUCTION

English

● This product should not be thrown in the garbage. In accordance with the European directive 2012/19/EU, electronic equipment at the end of their life must be collected & returned to an authorized recycling facility. ● Este producto no debe desecharse en la basura. De acuerdo a la directiva europea 2012/19/EU, los equipos electrónicos al final de su vida se deberán recoger y trasladar a una planta de reciclaje autorizada. ● Dieses Produkt sollte nicht mit dem Hausmüll entsorgt werden. In Übereinstimmung mit der europäischen Richtlinie 2012/19/EU müssen elektronische Geräte am Ende ihrer Lebensdauer eingesammelt und einem autorisierten Recyclingbetrieb zugeführt werden.

Thank you for purchasing this product. Please read the manual carefully before operating and keep this manual for future reference.
Statement: The company reserves the right to improve & upgrade products, product specifications and design are subject to change without notice.

Made in China

01 02

Main Unit Dimensions	L147*W143*H106mm ±5mm
Operating Ambient Temperature	0~40°C/32°F~104°F
Temperature Range	90°C~450°C/194°F~842°F
Display	LCD
Tip To Ground Resistance	<2 Ohms

I. Applications

This unit is suitable for de-soldering and soldering operations on various surface-mount components and through-hole components, such as SOP, DIP, SOIC, etc.

II. Product Diagram

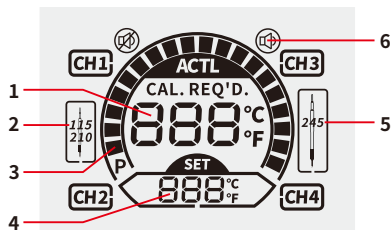

1. Actual Temperature
2. Soldering Iron Indicator (115/210)
3. Simulated Power (Soldering Iron)
4. Set Temperature
5. Soldering Iron Indicator (245)
6. Buzzer Indicator
7. Groove (For Heating Element Change)
8. Memory Channel Buttons CH1/CH2/CH3/CH4
9. Function Knob
10. Residual Tray
11. Tip Cleaner
12. Soldering Iron
13. Soldering Iron Holder
14. Cable Guide
15. Power Switch
16. Receptacle (Power Supply)
17. Locking Screw for Cable Guide
18. Receptacle (Soldering Iron)

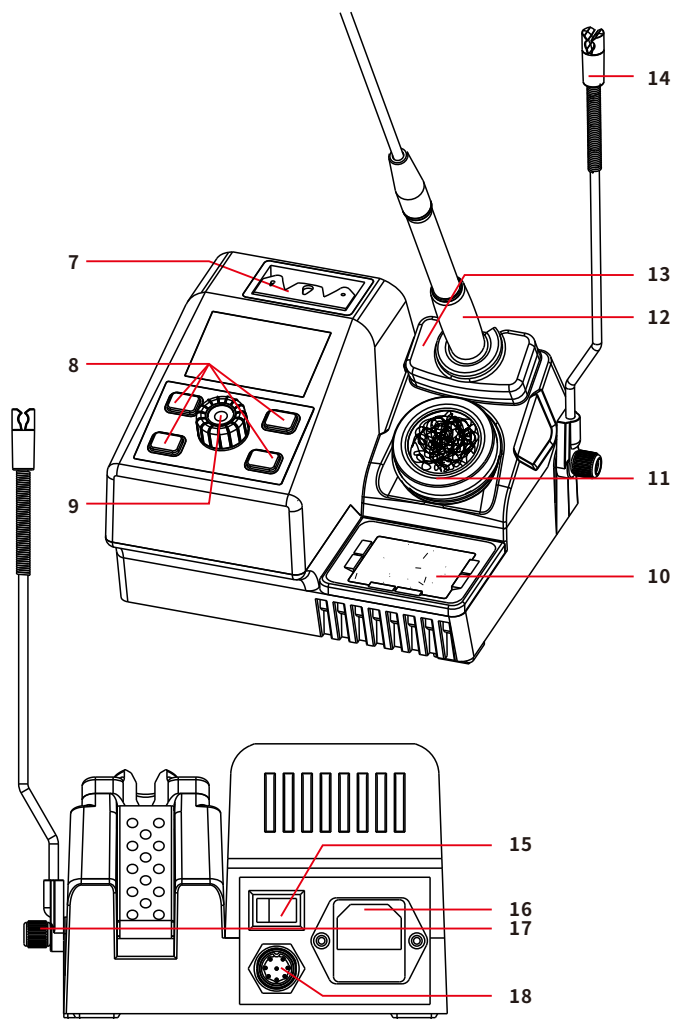

III. Operation Instructions

1. Changing Heating Element

Slot the soldering iron tip into the V-shaped groove (1-1), Pull the soldering iron to separate the heating element (1-2), Attach the new heating element to the soldering iron (1-3), Place the soldering iron tip into the hole and apply gentle pressure to secure the tip to the soldering iron (1-4).

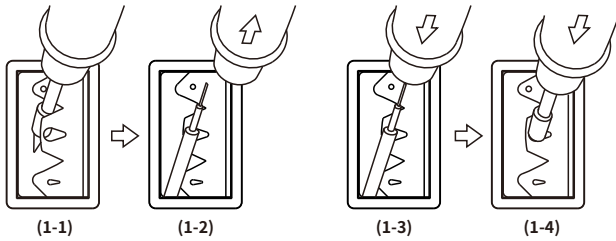

WARNING: When replacing the heating element during the operation (heated), DO NOT touch the heating element or the groove to avoid potential burn injuries. DO NOT place an operational heating element on the heating element groove for an extended period.

2. Connect the soldering iron and place the soldering iron into the soldering iron holder.

3. Place the solder wire dispenser on the left side of the station and align the dispenser to the installation hole located on the left side of the station. Secure both the dispenser and the station, ensure the dispenser is aligned parallel with the station. Then, install and tighten the screw.

4. Connect the station to a power socket and turn ON the power switch. The soldering station's heating element will begin heating as per normal, and the operation indicator turns ON. When the temperature is stabilized, it is ready for use.

CAUTION: Upon the first use of the soldering iron, set the temperature to 250°C/482°F. When the iron is just hot enough to melt solder, coat the soldering iron tip with a layer of solder (the use of rosin core solder is recommended), then set the temperature to your desired temperature.

5. When the operation is complete, use a damp sponge or metal wool ball to clean the residues off the soldering iron tip. Tin the soldering iron tip with a new layer of solder again, then put the soldering iron back to the holder. Turn OFF power switch and DISCONNECT the power cord if the station is not in use for an extended period.

03 04

05 06

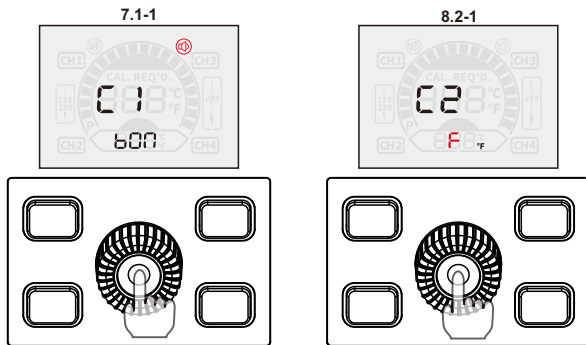

8. Fahrenheit/Celsius Temperature Display

8.1 Turn ON the power switch. Press and hold the function knob for approximately 2 seconds, and the display will show value "bON" or "bOF".

8.2 Press the function knob again and the display will show value "C" or "F" (8.2-1).

8.3 Turn the function knob to select either the Fahrenheit or Celsius temperature display mode.

8.4 Once done setting, press the function knob, and the system will automatically save the data and exit the setting interface.

9. Memory Channels CH1/CH2/CH3/CH4

You can preset temperature configurations in each memory channel for different needs. When soldering, you can select the suitable preset temperature configurations in CH1/CH2/CH3/CH4 quickly according to different soldering applications.

9.1 Press the CH1/CH2/CH3/CH4 memory channel button to choose the memory channel.

9.2 Turn the function knob to set the desired temperature. Once done setting, wait for approximately 4 seconds. -Setting complete

10. Automatic Shut-down

The soldering iron enters sleep mode when placed inside the soldering iron holder. At this point, the station's CPU will begin countdown. If the soldering is not picked up within approximately 30 minutes, the soldering station will automatically shut off. To restart the soldering station, please pick up the soldering iron.

6. Digital Temperature Calibration

Temperature discrepancies may occur due to the change in the environment's temperature or due to the replacement of the heating element and other components. You can correct the discrepancies with this function. The temperature calibration can help improve work efficiency and extend the lifespan of the soldering iron.

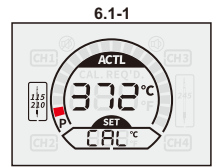

6.1 When the soldering station's temperature is stabilized, press and hold CH1 and Ch2 button for approximately 2 seconds, the display will show value "CAL" and the set temperature (6.1-1).

6.2 Turn the function knob to enter the measured temperature (6.1-2).

6.3 Press the function knob to confirm the entry. The system will automatically calibrate the temperature and exit the calibration interface (6.1-3).

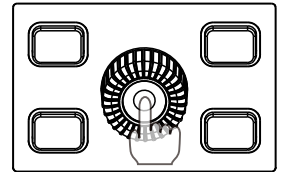
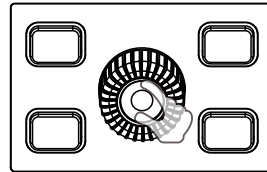
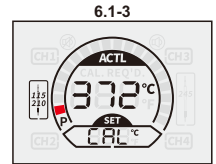
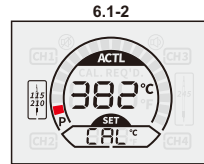
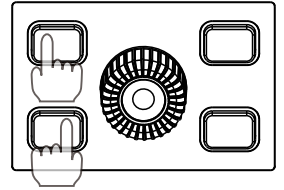

7. Buzzer Prompt

7.1 Turn ON the power switch, press and hold the function knob for approximately 2 seconds, the display will show "bON" or "bOF". The value "bON" indicates the buzzer is turned ON, and "bOF" indicates the buzzer is turned OFF (7.1-1).

7.2 Turn the function knob to turn the buzzer ON or OFF.

7.3 Once done setting, press the function knob twice, and the system will automatically save the data and exit the setting interface.

11. Sleep Mode

This function extends the lifespan of the heating element, conserves energy, and protects the environment.

When the soldering iron is placed back into the holder, the soldering iron will enter sleep mode. When the set temperature is 200°C/392°F or higher, the temperature will cool to 200°C/392°F; when the set temperature is below 200°C/392°F, the temperature will remain unchanged. Pick up the soldering iron to wake the station.

IV. Maintenance & Precautions

1. If a layer of oxidization forms on the surface of the soldering iron tip, a misconception can be created that the soldering tip cannot heat up properly to melt the solder and do the tinning. But the actual temperatures of both the heating element and soldering tip are high. In this instance, DO NOT increase the temperature value further, but use a metal wool ball to remove the oxidization following the steps below:

A. Set the temperature to 300°C (572°F).

B. Once the temperature stabilizes, gently rub the soldering iron tip inside the metal wool ball.

C. When the oxidization is partially removed, continue applying solder onto the tip while rubbing it until the soldering tip is completely coated with solder. If the tip is too severely oxidized beyond cleaning, replace the tip with a new one.

2. DO NOT use metal files to remove the oxidization on the soldering iron tip. If the soldering iron tip deforms or rusts, replace the soldering iron tip with a new tip.

3. DO NOT apply excessive forces on the soldering tip when soldering. Doing so will NOT improve heat transfer but damage the soldering iron tip instead.

4. Clean the soldering iron tip after use and tin the tip with a new layer of solder to prevent oxidization.

V. Troubleshooting

This is an indication that the station's sensor module is faulty. You need to replace the heating element (the heating element and the sensor modules). Or, the soldering iron/heating element is not connected.